



MAGNUM MUD EQUIP. CO.

"FIRST IN SERVICE"

HOUMA, LA
1-800-230-8265

JENNINGS, LA
1-800-200-8265

COAST GUARD APPROVED TANKS • UN TANKS
IMDG STAINLESS TANKS • IM-101 TANKS

CARGO TANKS • STORAGE TANKS
CUTTINGS BOXES • D.O.T. SPEC. 57 TANKS

CARGO CONTAINERS
IBC WASTE DISPOSAL CONTAINERS

OFFSHORE TOOL BASKETS
PALLET CARGO BOXES

PORTABLE MUD MIXING PLANTS
DNV CERTIFIED EQUIPMENT

Member of



AECGA
AMERICAN ENERGY CARGO CONTAINER ASSOCIATION

www.magnummud.com

Servicing the Gulf of Mexico Since 1981



Commitment to Our Customers

Magnum Mud Equipment Co., Inc. began operations in 1981. Since then we have been providing state of the art equipment to the Gulf Coast area. Success is defined by continually creating and delivering value to the customer, and that is what Magnum Mud Equipment Co., Inc. has continued to achieve over the years. We are continually reinventing ourselves with services and equipment that our customers need, which is the main reason that we have been able to survive so long in this industry.

Even in 2016 and 2017, some of the toughest years in our industry, Magnum Mud Equipment Co. Inc. was still able to reinvest in the industry by fabricating newly designed equipment. One particular design is our new 15bbl. IBC Waste Disposal Container. It is the latest development in transportation of waste oil from production vessel cleanouts.

If you have used us in the past, we appreciate your business. If not, please give us a try and see first-hand how our service and equipment sets us apart from our competition.

8 Locations to Serve You

Logistics can be a complicated task for Operators and Service Companies working in the Gulf of Mexico. In order to make it easier to get the job done in a timely and cost efficient manner, Magnum Mud Equipment Co., Inc. operates facilities in Venice, Fourchon, Houma, Morgan City, Intracoastal City, Jennings, Cameron and Galveston. In addition, we offer free local delivery and pick up of the equipment we stock in Venice, Fourchon, and Cameron. We are sure to have what you need, where you need it.

Compliance: In today's industry, Compliance of equipment is of the utmost importance. Magnum Mud Equipment Co., Inc. has a vast database consisting of every piece of equipment we own and test/inspection dates associated with each piece of equipment. We also have online certificates available on our equipment. By simply visiting our website at www.magnummud.com, the certification of each sling, tank or any other type of equipment can be quickly loaded and printed if needed.

“Service is defined by continually creating and delivering value to the customer.”



1. Venice, Louisiana
2. Fourchon, Louisiana
3. Morgan City, Louisiana
4. Intracoastal City, Louisiana
5. Cameron, Louisiana
6. Galveston, Texas
7. Jennings, Louisiana
8. Houma, Louisiana

Table of Contents

	Page #
D.O.T. and U.S.C.G. Approved Tanks	
350 gallon	2
550 gallon	2
550 gallon	3
25 bbl.	3
25 bbl.	4
25 bbl.	4
100 bbl.	5
150 bbl.	6
250 bbl.	7
500 bbl.	9
15 bbl.	10
15 bbl.	11
25 bbl.	12
Logistics Equipment	
4' x 4' Cargo Container.....	13
Magnum Single Pallet-Cargo Box w/ Water Tight Door.....	13
Side By Side Pallet Box.....	14
Magnum Dual Pallet-Cargo Box.....	14
DNV 6' x 6' Offshore Transport Box.....	15
DNV 8' x 10' Offshore Transport Box.....	15
8' x 20' Double Door Cargo Container.....	15
DNV Baskets.....	16
4' x 4' Offshore Tool Basket.....	17
4' x 8' Offshore Tool Basket.....	17
4' x 12' Offshore Tool Basket.....	17
4' x 16' Offshore Tool Basket.....	17
4' x 24' Offshore Tool Basket.....	17
4' x 40' Offshore Tool Basket.....	17
4' x 50' Offshore Tool Basket.....	17
4' x 76' Offshore Tool Basket.....	Not Shown
6' x 8' Offshore Tool Basket.....	17
6' x 12' Offshore Tool Basket.....	17
6' x 16' Offshore Tool Basket.....	17
8' x 8' Octagon Hose/Material Basket.....	18
8' x 16' Offshore Tool Basket.....	18
8' x 24' Offshore Tool Basket.....	18
8' x 28' Offshore Tool Basket With Removable Side.....	18
12' x 27' Offshore Tool Basket.....	18
4' x 12' Subsea Basket.....	18
4' x 16' Subsea Basket.....	18
8' x 16' Subsea Basket.....	18
8' x 24' Subsea Basket.....	18
8' x 16' Magnum Transporter.....	19
8' x 24' Magnum Transporter.....	19
Bottle Rack.....	20
6' x 6' Mini-Transporter.....	20
Drum Carrier.....	21
Tote Tank Carrier.....	21
Sling Rack.....	22
Grating Carrier.....	22
8 Way Low Pressure Manifold.....	24
8 Way High Pressure Manifold.....	24
Mixing Tanks	
50 bbl.Open Top Mx. Blend. Tank w/Hydraulic Agitator.....	23
Storage Tanks	
25 bbl.Open Top Storage Tank.....	Not Shown
50 bbl.Open Top Storage Tank.....	Not Shown
50 bbl.Open Top Mx. Tank.....	Not Shown
100 bbl.Open Top or L Skid Encl. Storage.....	Not Shown
100 bbl.Open Top Mx. Tank.....	Not Shown
150 bbl.Open Top Storage Tank.....	Not Shown
200 bbl.Open Top Storage Tank.....	Not Shown
Portable Pumps	
3' x 3' Air Diaphragm Pump.....	Not Shown
5' x 6' Centrifugal Pump w/371 Diesel Engine Electric Start.....	Not Shown
5' x 6' Centrifugal Pump w/371 Diesel Engine Electric Start and Independent Hydraulic Power Pack.....	Not Shown
6' x 8' Centrifugal Pump w/471 Diesel Engine Electric Start.....	Not Shown
6' x 8' Centrifugal Pump w/671 Diesel Engine Electric Start.....	Not Shown

“We Are The Tank Rental Professionals”

350 GALLON STAINLESS STEEL IBC TOTE TANK



FEATURES:

- 10 Gauge Construction
- Base Dimensions 42" x 48"
- Total Height (approx) 50"
- Volume (approx) 350 gallons (1325 liters)
- Empty Weight (approx) 500 lbs.
- Maximum Gross Weight 6,000 lbs.
- 22.5" Nominal Diameter Stainless Steel Removable Lid with Eyebrows (for fork deflection) and a 2" Crimp-on Vent Cap
- EPDM Multi-seal Lid Gasket
- Epoxy-coated Manway Clamp Ring
- Standard 1/4" Combination Lifting Lug / Leg Positioner
- 2" Top Bung Fitting with Plug and Buna Gasket
- Sloped Bottom Construction for Virtually Complete Product Drainage
- 2" 316 Stainless Steel Reverse Acting, Lockable Ball Valve with Plastic Shipping Plug and Valve Guard for Forklift Protection
- Plated Steel 5/8" x 4" Bolt and 5/8" Nut
- Safety / Caution Decals
- Stainless Steel UN/Serial Number Plate

550 GALLON STAINLESS STEEL IBC TOTE TANK



FEATURES:

- 10 Gauge Construction
- Base Dimensions 42" x 48"
- Total Height (approx) 74"
- Volume (approx): 550 gallons (2084.50 liters)
- Empty Weight (approx) 669 lbs.
- Maximum Gross Weight 9,400 lbs.
- 22.5" Nominal Diameter Stainless Steel Removable Lid with Eyebrows (for fork deflection) and a 2" Crimp-on Vent Cap
- EPDM Multi-seal Lid Gasket
- Epoxy-coated Manway Clamp Ring
- Standard 1/4" Combination Lifting Lug / Leg Positioner
- 2" Top Bung Fitting with Plug and Buna Gasket
- Sloped Bottom Construction for Virtually Complete Product Drainage
- 2" 316 Stainless Steel Reverse Acting, Lockable Ball Valve with Plastic Shipping Plug and Valve Guard for Forklift Protection
- Plated Steel 5/8" x 4" Bolt and 5/8" Nut
- Safety / Caution Decals
- Stainless Steel UN/Serial Number Plate

****Also available in
126 gallon capacity***

See our Tote Tank Carrier on page 21.



DNV 550 GALLON IMDG TANK

FEATURES:

- IMDG (T11) UN Class Certification
- DIM 52"L x 5'2"W x 7'11"H
- Empty Weight 2,645 lbs.
- Maximum Gross Weight 13,228 lbs.
- M.A.W.P. 58 PSI
- DNV 2.71 Approved 4-Point Lift
- 2" Camlock Discharge
- Fall Protection

DNV 25 BARREL IMDG TANK

FEATURES:

- IMDG (T11) UN Class Certification
- DIM - 6'6"L x 6'6"W x 8'6"H
- Empty Weight 4,190 lbs.
- Maximum Gross Weight 26,000 lbs.
- M.A.W.P. 58 PSI
- DNV 2.71 Approved 4-Point Lift
- 3" Camlock Discharge
- Fall Protection

Optional Level Indicator Gauge



Magnum Mud Equipment Co. Inc. recognizes the need in our industry for specialized tanks to transport specialized products. In addition to our 25BBL stainless steel IMDG tanks, our new 550 Gallon stainless steel IMDG tanks offer many benefits for transportation of expensive specialty fluids or hazardous products that require the safety features of IMDG tanks. These tanks have many safety features built into the design such as internal valves with both remote closure and fusible links, should a fire occur. The grated work area and fall arrest anchor device work together to supply a safe area for workers when filling or rigging the tank. Lastly, these tanks have no internal liners to worry about. Give us a call so we can answer any questions that may arise concerning our stainless steel IMDG tanks.

“Service With Experience”

25 BARREL UN TANK

FEATURES:

- 8'6" L X 6' W X 7'2" H
- Empty Weight 6,500 lbs.
- Maximum Gross Weight 28,000 lbs.
- M.A.W.P. 58 psi
- 3" Internal Valve
- Camlock Fittings
- Epoxy Lining
- 4 - Point Lift
- Forklift Slots
- Fusible Link
- Walkway Grating
- Fall Protection



25 BARREL D.O.T. CERTIFIED IM 101 TANK

FEATURES:

- 8'6" L x 5'3" W x 7'5" H
- Empty Weight 4000 lbs.
- Maximum Gross Weight 25,000 lbs
- Protective frame around tank allows tanks to be stackable when empty
- Epoxy lined for easier cleaning
- Internal valve & remote closure
- Top of tank has non-skid surface for safety
- * Tank height is less than 6' from the ground, therefore no harness is required.



4 Bar IM101 Tanks can be provided upon request.

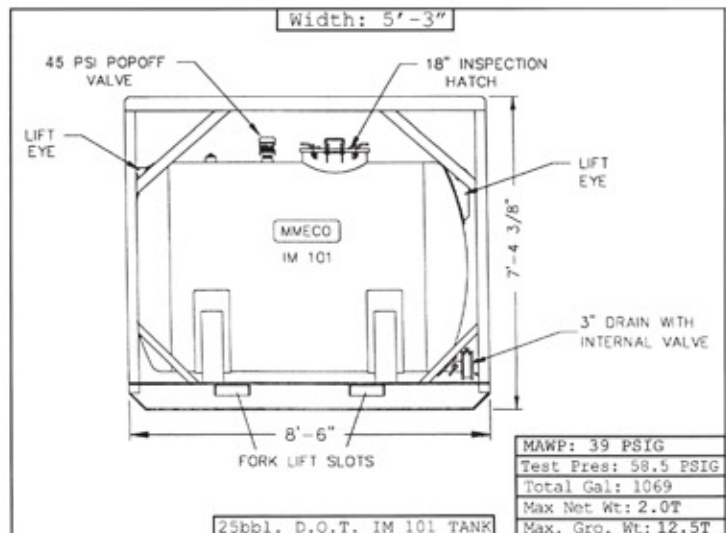

Largest inventory of offshore transport tanks on the Gulf Coast.



100 BARREL D.O.T. CERTIFIED IM 101 TANK



FEATURES:

Maximum Gross Weight 56,500 lbs.
Epoxy Lined for Easier Cleaning
Top of Tank Has Non-skid Surface
for Safety
Fall Protection

*Can be lifted with fluid
up to a MGW of 56,000 lbs.*

**IM 101
CERTIFIED**

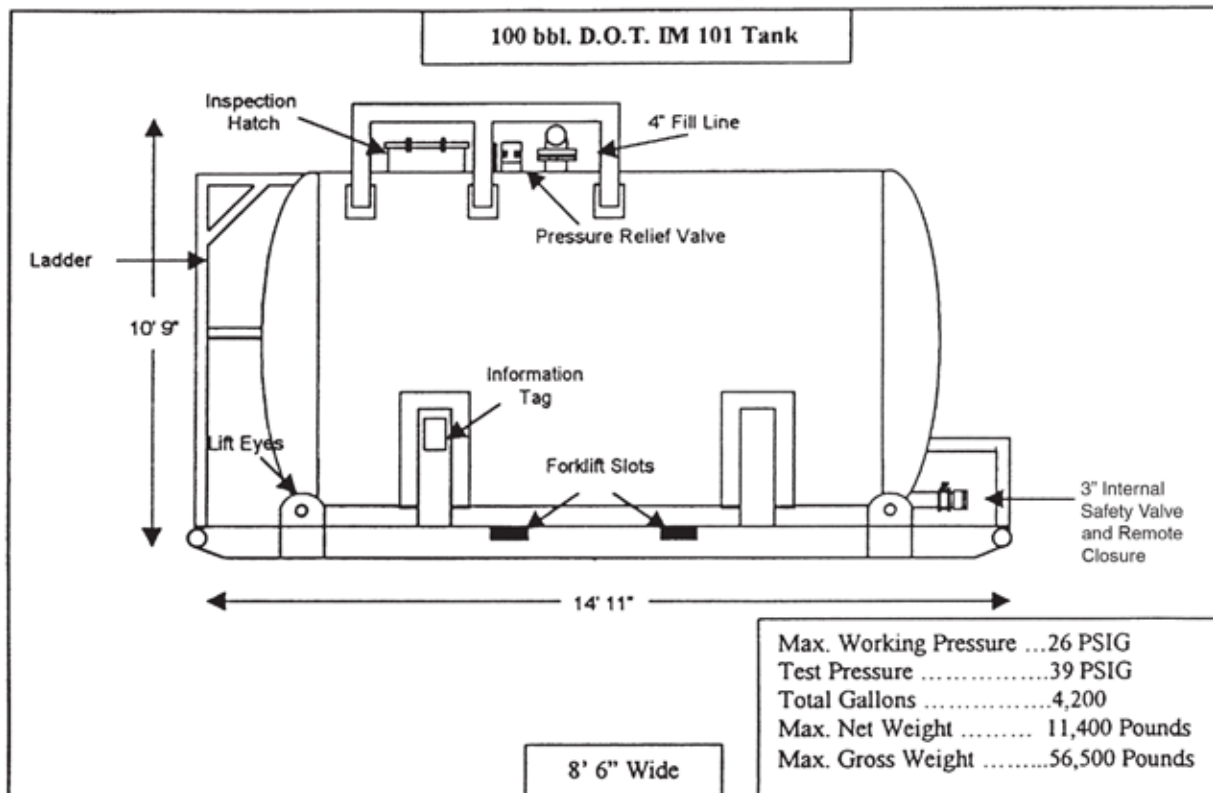

“Best Design and Strongest Built”

150 BARREL D.O.T. CERTIFIED IM 101 TANK

FEATURES:

- Maximum Gross Weight 80,000 lbs.
- Epoxy Lined for Easier Cleaning
- Top of Tank has Non-skid Surface for Safety
- Fall Protection

**IM 101
CERTIFIED**

*Can be lifted with
fluid up to a MGW
of 80,000 lbs.*

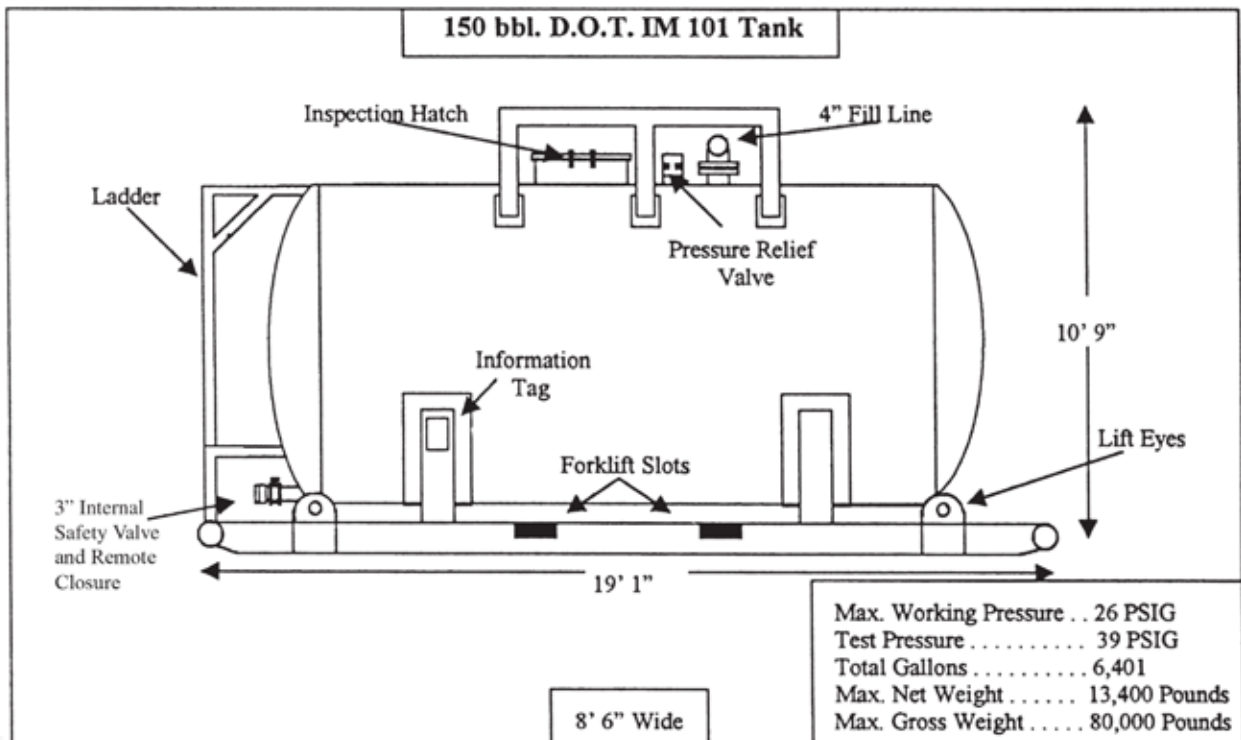

We Can Handle the Big Jobs Too



250 BARREL U.S.C.G. APPROVED INDEPENDENT CARGO TANK WITH HAND RAILS

FEATURES:

- Suction Line
- Fill Line
- Available with Circulating Line upon Request

**Sight glass available upon request.*

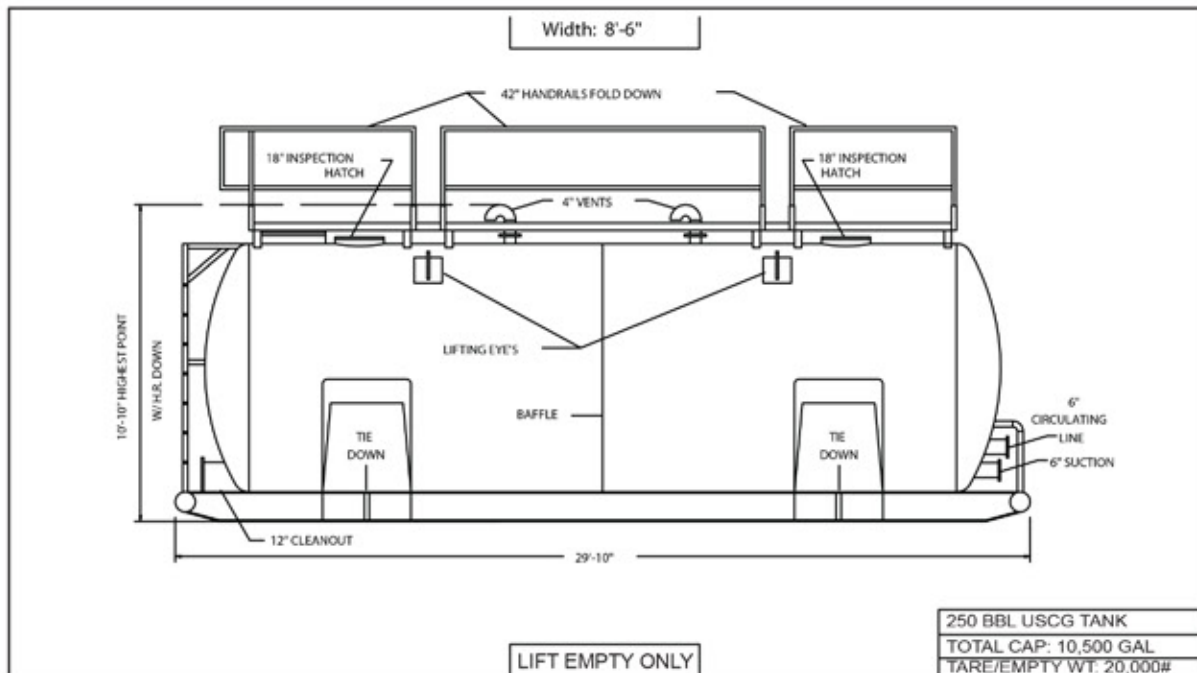

We Specialize in Flowback Equipment

8-Way Low Pressure Manifold p. 24



High Pressure Manifold p. 24



2", 3", or 4" Hoses



Drip Pans



Pumps



4" ERL Relief Valve



4" Inline Flame Arrester



4" Tank Mounted Flame Arrester



All MMECO Baskets Are Designed With 2.5 to 1 Safety Factor



500 BARREL U.S.C.G. APPROVED INDEPENDENT CARGO TANK WITH HAND RAILS



FEATURES:

- Suction Line
- Fill Line
- Walkway with Handrails
- Available with Circulating Line upon Request

**Sight glass available upon request.*

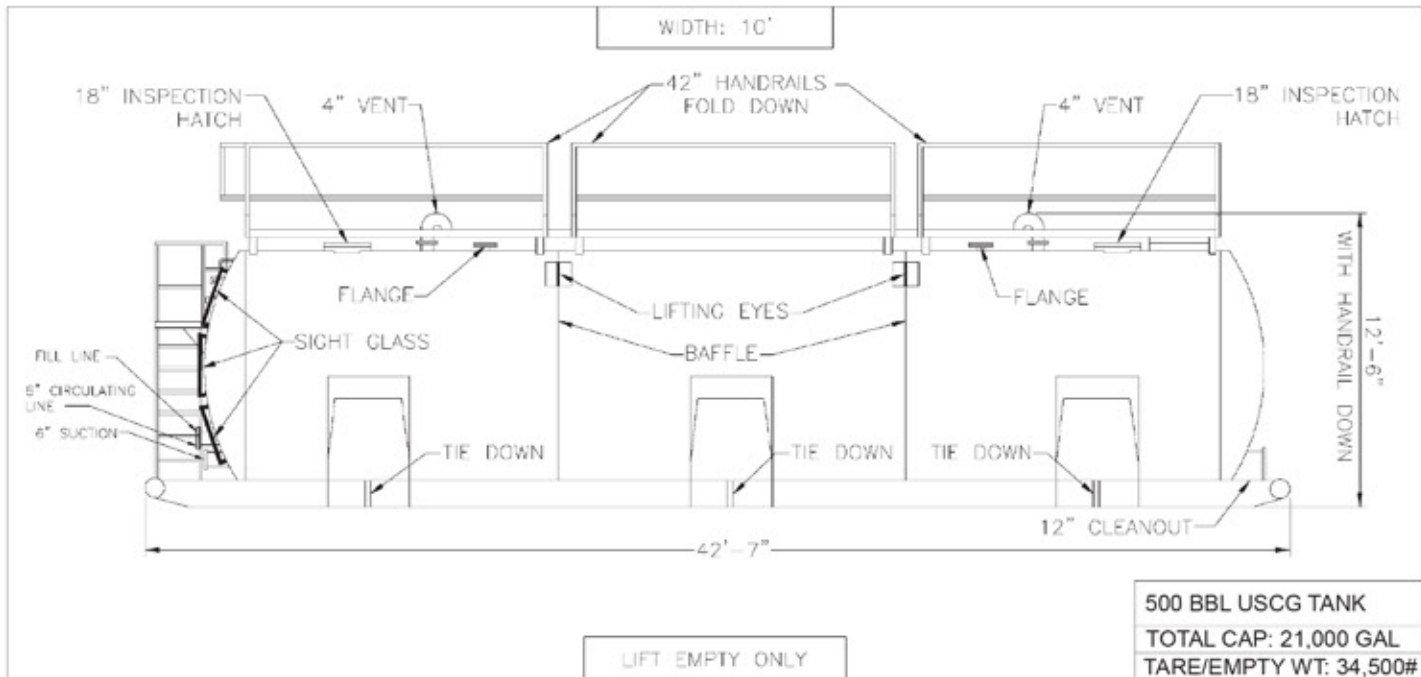

15 BARREL D.O.T. SPEC. 57 CUTTINGS BOX



FEATURES:

- Low Profile
- Tank Galvanized for Easy Cleaning
- Stackable Design for Saving Space
- Inspection Hatch
- Fork Lifiable on All 4 Sides
- Designed, Manufactured and Tested to Meet or Exceed D.O.T. Requirements

TANK USED FOR:

- Transporting Materials Offshore
- Transporting Materials on Highways

APPROVED FOR TRANSPORTING:

- NORM Waste
- Oil Base Drill Cutting
- Many Other Industrial Hazardous Wastes

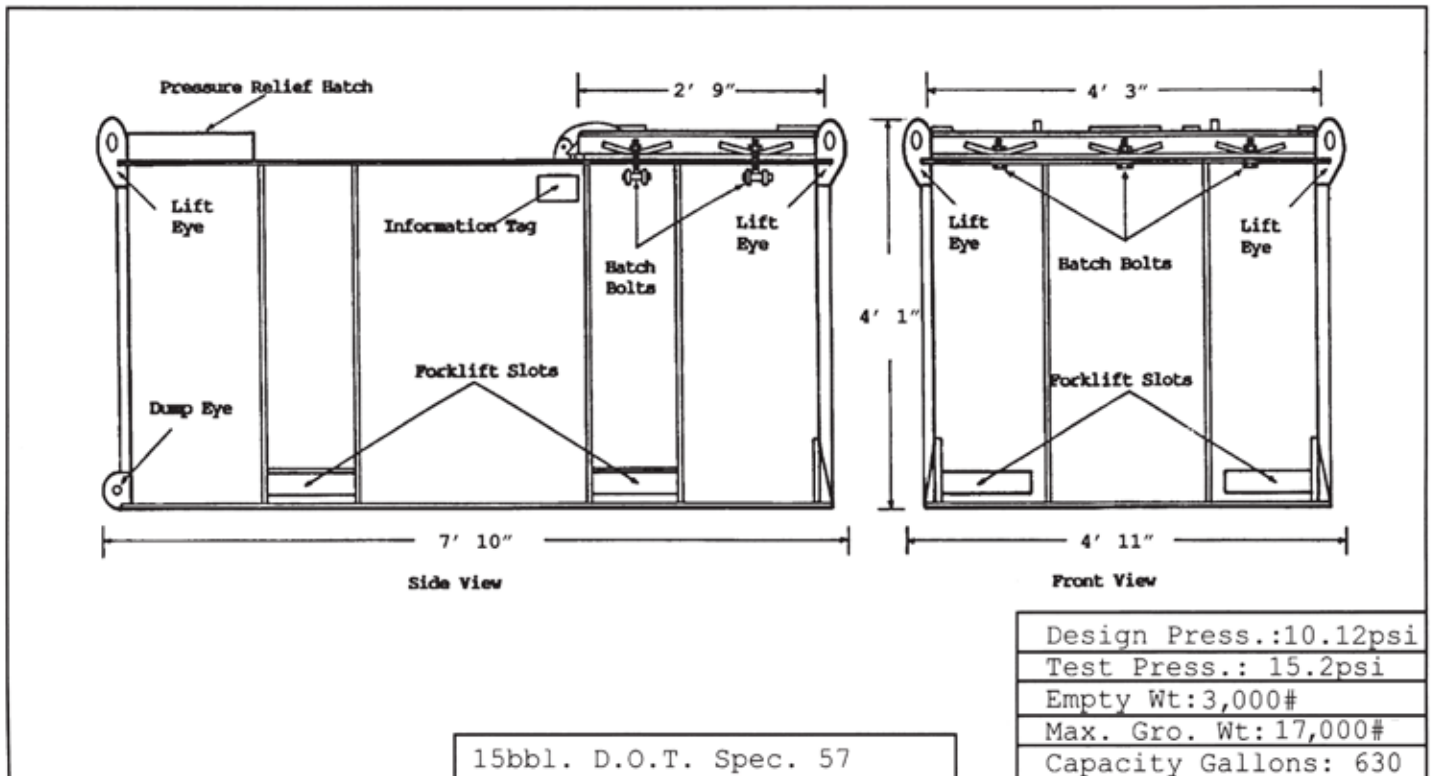

15bbl. D.O.T. Spec. 57

IBC's Can Legally Transport Waste



15 BARREL DNV / IBC WASTE DISPOSAL CONTAINER



FEATURES

Carries the Intermediate Bulk Container "IBC" classification.

Recognized in both IMDG Code Volume 1, Chapter 6.5 and in the United States Department of Transportation in 49 CFR Section 178.700.

Used for transporting waste from production vessel cleanouts.

Fitted with a smaller and lighter lid than conventional cuttings boxes, making it safer for personnel to use.

Internationally recognized designation. The IBC Specification Mark for this new container is UN 31AY/06-18/USA/M5281/14696/8165.

SPECIFICATIONS:

8'0"L x 5'7³/₄"W x 4'2⁹/₄"H

Capacity 630 Gallons

Tare Weight 5,400 lbs.

Payload 12,600 lbs.

Maximum Gross Weight 18,000 lbs.



25 BARREL D.O.T. NON SPEC. CUTTINGS BOX



FEATURES:

- Low Profile
- Tank Galvanized for Easy Cleaning
- Stackable Design for Saving Space
- Inspection Hatch
- Fork Lifiable on All 4 Sides
- Designed, Manufactured, and Tested to Meet or Exceed D.O.T. Requirements

TANK USED FOR:

- Transporting Materials Offshore
- Transporting Materials on Highways

APPROVED FOR TRANSPORTING:

- Combustible Liquids

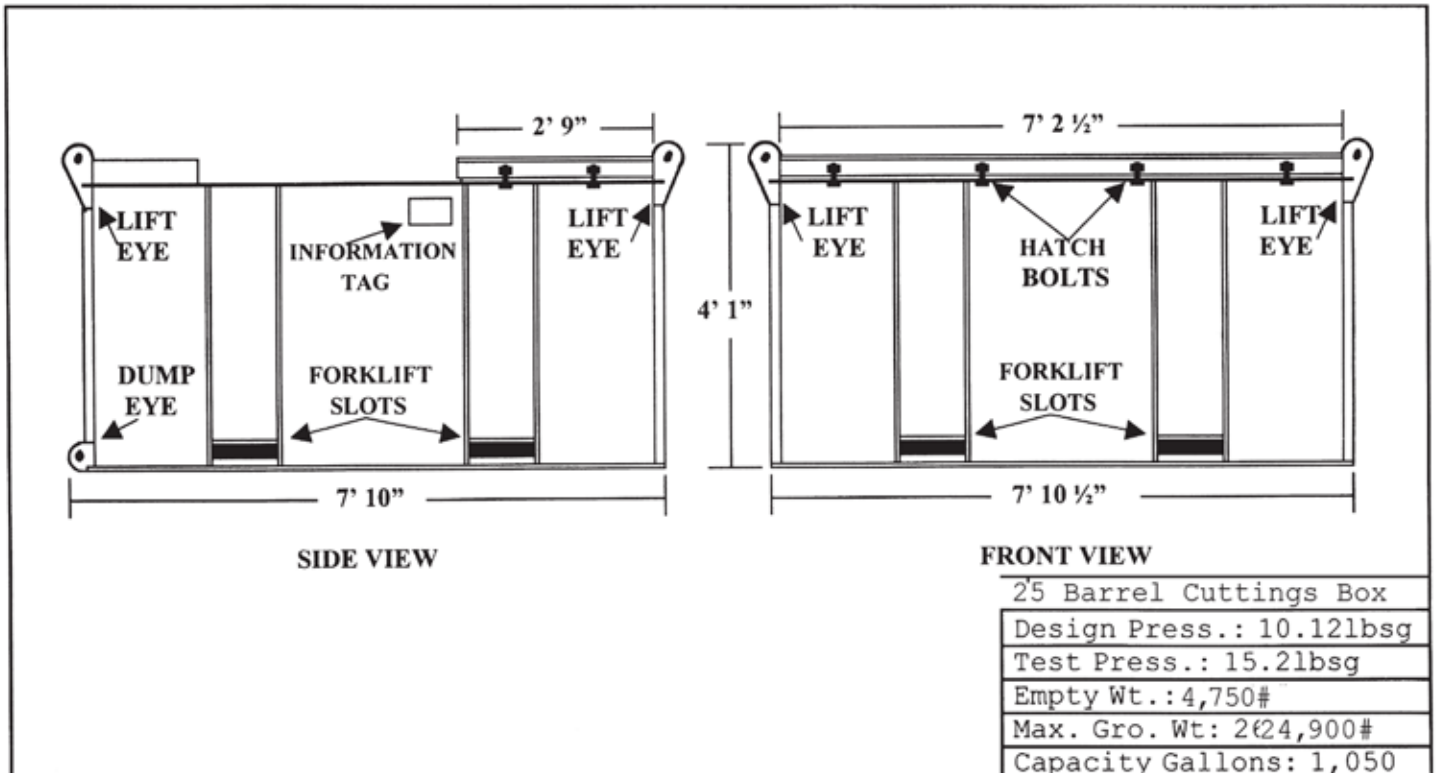

“Service With Experience”



4X4 CARGO BOX

DIMENSIONS 4'W x 4'L x 7'1"H
APPROX. WEIGHT 2,150 lbs.

FEATURES:

- Maximum Gross Weight 10,000 lbs.
- Stackable Design (Empty Only)
- Lockable Door
- Forklift Slots
- Designed with 2.5 to 1 Safety Factor
- Engineered Padeyes
- Waterproof Doors
- Galvanized Coating
- 4 Leg Sling



SINGLE PALLET/CARGO BOX

DIMENSIONS 6'9"H x 5'8"W x 5'11"D • APPROX. WEIGHT 3,000 lbs.



FEATURES:

- Maximum Gross Weight 10,000 lbs.
- Designed with 2.5 to 1 Safety Factor
- Engineered Padeyes
- Waterproof Door
- 2 Lockable Door Latches with Grease Fittings
- Internal Door Latches
- 2-4" Forklift Slots
- Stackable Design (Empty Only)
- Internal Cargo Tie Down Rings
- Waterproof Vent
- Galvanized Coating
- 4 Leg Sling

*Also available for battery service.
Also available in DNV.*

Large and Small Cargo Containers

SIDE BY SIDE PALLET BOX

DIMENSIONS 6'9"H x 10'10"W x 5'8"D
APPROX. WEIGHT 6,000 lbs.



FEATURES:

- Maximum Gross Weight 22,000 lbs.
- Stackable Design with 2 Independent Locking Doors
- Waterproof Doors
- 2 - 4" Forklift Slots
- Internal Cargo Tie Downs
- Waterproof Vent
- Galvanized Coating
- Engineered Padeyes

DUAL PALLET/CARGO BOX

DIMENSIONS 10'2"H x 5'4"W x 5'8"D • APPROX. WEIGHT 4,300 lbs.

FEATURES:

- Maximum Gross Weight 17,200 lbs.
- Designed with 2.5 to 1 Safety Factor
- Engineered Padeyes
- Large Easy Open Door
- Lockable Door Latch
- Internal Door Latch
- 2-4" Forklift Slots
- Internal Cargo Tie Down Rings
- External Tie Downs to Secure Box During Transportation
- Galvanized Coating
- Removable Shelf
- 4 - Leg Sling with Stinger

Common Uses:

- Transport, contain, and lift pallet material
- Transport, contain, and lift bulk sack material
- Transport miscellaneous items such as office equipment and computers

Also available in DNV



“We Can Handle All Your Cargo Container Needs”



DNV 6X6 OFFSHORE TRANSPORT BOX

DIMENSIONS 7'3"H x 6'5"W x 6'D
APPROX. WEIGHT 4,298 lbs.

FEATURES:

- Maximum Gross Weight 8,818 lbs.
- Stackable Design (Empty Only)
- Lockable Door
- Tie Down Loops
- Forklift Slots
- Engineered Padeyes
- Waterproof Doors
- Vent on Each Side



DNV 8x10 OFFSHORE TRANSPORT BOX

DIMENSIONS 9'10"L x 8'W x 8'6"H
APPROX. WEIGHT 6,830 lbs.

FEATURES:

- Maximum Gross Weight 28,660 lbs.
- Forklift Slots
- Lockable Door Latches
- Engineered Padeyes
- 4 Interior Tie-Down Loops
- Stackable Design (Empty Only)
- Vent on Each Side



8x20 CARGO CONTAINER

DIMENSIONS 19'11"L x 8'W x 8'6"H • APPROX. WEIGHT 5,000 lbs.

FEATURES:

- Maximum Gross Weight 29,000 lbs.
- CSC Safety Approval
- Waterproof Doors
- Lockable Door Latches
- Wood Flooring
- Interior Tie-Down Loops
- Vent on Each Side
- Forklift Slots
- Engineered Pad Eyes
- Stackable Design (Empty Only)

Common Uses:

- Transport and store miscellaneous cargo (i.e.: furniture, office supplies, pallet material)
- Store and secure cargo at the dock



Now Offering a Full Line of DNV Baskets

DNV BASKETS



4' x 12'
EMPTY WEIGHT: 3,000 lbs.
MAX GROSS WEIGHT: 12,000 lbs.



4' x 8'
EMPTY WEIGHT: 2,050 lbs.
MAX GROSS WEIGHT: 12,000 lbs.



4' x 24'
EMPTY WEIGHT: 6,000 lbs.
MAX GROSS WEIGHT: 16,000 lbs.



4' x 76'
EMPTY WEIGHT: 14,100 lbs.
MAX GROSS WEIGHT: 40,000 lbs.



6' x 12' w/ removable side
EMPTY WEIGHT: 4,800 lbs.
MAX GROSS WEIGHT: 24,800 lbs.



6' x 16' w/ removable side
EMPTY WEIGHT: 5,800 lbs.
MAX GROSS WEIGHT: 24,800 lbs.



8' x 16' w/ removable side
EMPTY WEIGHT: 6,500 lbs.
MAX GROSS WEIGHT: 26,500 lbs.



8' x 24' w/ removable side
EMPTY WEIGHT: 11,500 lbs.
MAX GROSS WEIGHT: 40,000 lbs.



12' x 27'
EMPTY WEIGHT: 12,300 lbs.
MAX GROSS WEIGHT: 68,000 lbs.

Baskets of All Sizes



4' x 4'
EMPTY WEIGHT: 1,450 lbs.
MAX GROSS WEIGHT: 6,000 lbs.



4' x 8'
EMPTY WEIGHT: 2,050 lbs.
MAX GROSS WEIGHT: 12,000 lbs.



4' x 12'
EMPTY WEIGHT: 2,500 lbs.
MAX GROSS WEIGHT: 12,000 lbs.



4' x 16'
EMPTY WEIGHT: 3,900 lbs.
MAX GROSS WEIGHT: 12,000 lbs.



4' x 24'
EMPTY WEIGHT: 4,400 lbs.
MAX GROSS WEIGHT: 13,000 lbs.



4' x 40'
EMPTY WEIGHT: 7,600 lbs.
MAX GROSS WEIGHT: 40,000 lbs.

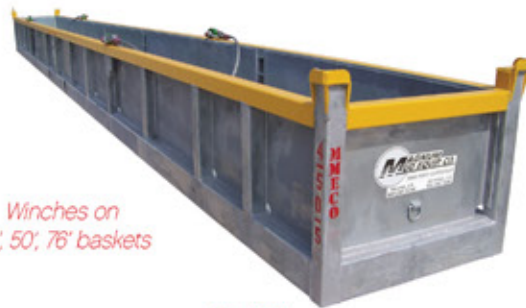

Winches on
40', 50', 76' baskets

4' x 50'
EMPTY WEIGHT: 9,200 lbs.
MAX GROSS WEIGHT: 40,000 lbs.
(4' x 76' Not shown)



6' x 8'
EMPTY WEIGHT: 2,500 lbs.
MAX GROSS WEIGHT: 15,000 lbs.



6' x 12'
EMPTY WEIGHT: 3,400 lbs.
MAX GROSS WEIGHT: 23,800 lbs.



6' x 16'
EMPTY WEIGHT: 4,200 lbs.
MAX GROSS WEIGHT: 24,800 lbs.

Also available
4'x76'

All MMECO Baskets Are Designed With 2.5 to 1 Safety Factor



8' x 8' Octagon Hose Basket
EMPTY WEIGHT: 2,650 lbs.
MAX GROSS WEIGHT: 12,500 lbs.



8' x 16'
EMPTY WEIGHT: 5,700 lbs.
MAX GROSS WEIGHT: 26,500 lbs.



8' x 24'
EMPTY WEIGHT: 8,600 lbs.
MAX GROSS WEIGHT: 40,000 lbs.



8' x 28' w/removable side
EMPTY WEIGHT: 11,500 lbs.
MAX GROSS WEIGHT: 45,000 lbs.



12' x 27'
EMPTY WEIGHT: 12,300 lbs.
MAX GROSS WEIGHT: 68,000 lbs.

SUBSEA BASKETS



4' x 12' Subsea Basket
EMPTY WEIGHT: 2,500 lbs.
MAX GROSS WEIGHT: 12,000 lbs.



8' x 24' Subsea Basket
EMPTY WEIGHT: 8,600 lbs.
MAX GROSS WEIGHT: 40,000 lbs.



8' x 16' Subsea Basket
EMPTY WEIGHT: 6,000 lbs.
MAX GROSS WEIGHT: 26,500 lbs.



4' x 16' Subsea Basket
EMPTY WEIGHT: 3,900 lbs.
MAX GROSS WEIGHT: 12,000 lbs.

**Also available in 4' x 24'*

8' X 16' TRANSPORTER

DIMENSIONS 16'L x 8'W x 5'8"H
EMPTY WEIGHT 5,000 lbs.

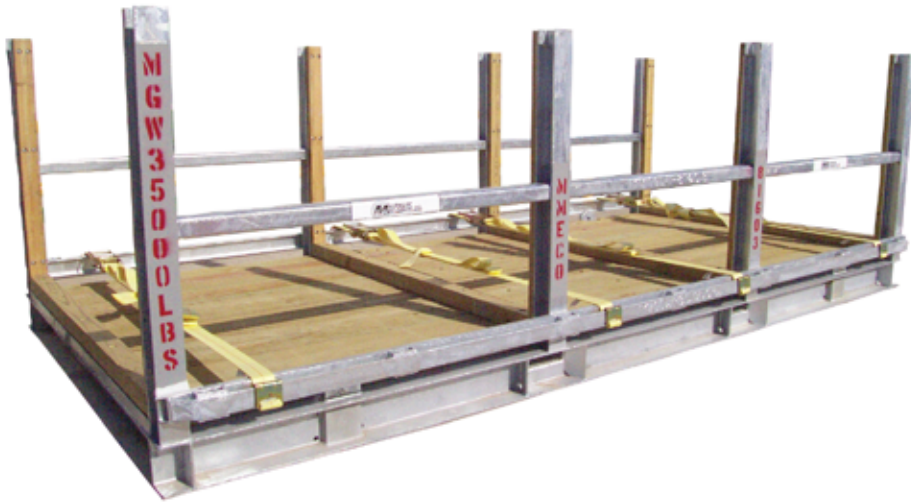

Common Uses:

- Safely transport, contain, and lift odd configured materials such as tubing reels, pipe, spools of cable, etc.
- Safely transport, contain, and lift multiple items to reduce the number of crane lifts

FEATURES:

Maximum Gross Weight 35,000 lbs.
Chain Pockets
4-3" Strap Binders
2-4" Forklift Slots
Hardwood Deck
Galvanized Coating
4-Leg Sling
Designed with 2.5 to 1 Safety Factor
Engineered Padeyes

8' X 24' TRANSPORTER

DIMENSIONS 24'L x 8'W x 5'8"H EMPTY WEIGHT 6,500 lbs.

Common Uses:

- Safely transport, contain, and lift odd configured materials such as tubing reels, pipe, spools of cable, etc.
- Safely transport, contain, and lift multiple items to reduce the number of crane lifts

FEATURES:

Maximum Gross Weight 40,000 lbs.
Chain Pockets
4-3" Strap Binders
2-4" Forklift Slots
Hardwood Deck
Galvanized Coating
4-Leg Sling
Designed with 2.5 to 1 Safety Factor
Engineered Padeyes



Locations all along the Gulf Coast.

BOTTLE RACK CARRIER

DIMENSIONS 6'5"H x 5'10"W x 5'1/2"D • EMPTY WEIGHT 2,000 lbs.

FEATURES:

- Maximum Gross Weight 3,800 lbs.
- Safely Transports 8 Oxygen Bottles and 2 Acetylene Bottles
- Fold Down Ramp to Ease Loading and Unloading
- 2" Ratchet Straps to Secure Bottles
- 4-Point Lift
- Engineered Padeyes

Also available in DNV.



MINI TRANSPORTER

DIMENSIONS 5'10"L x 5'10"W x 5'H • APPROX. WEIGHT 2,350 lbs.

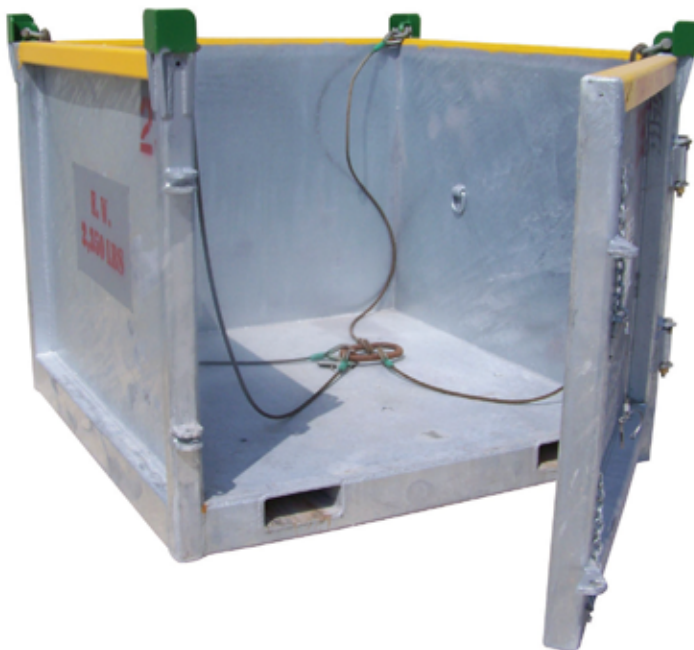

FEATURES:

- Maximum Gross Weight 10,000 lbs.
- Door Lock Pins with Positive Lock
- 2 - 4" Forklift Slots
- Stackable Design
- Internal Cargo Tie Down Rings
- Large Easy Open Door
- Galvanized Coating
- Engineered Padeyes
- Designed with 2.5 to 1 Safety Factor

Common Uses:

- Transport, contain, and safely lift up to four drums
- Transport, contain, and safely lift pallet material
- Transport, contain, and safely lift bulk sack material

Also available in DNV.

DRUM CARRIER

DIMENSIONS 3'10"H x 4'8"W x 5'2"D
EMPTY WEIGHT 1,400 lbs.



FEATURES:

- Maximum Gross Weight 6,000 lbs.
- 4 - Independent Lockable Doors
- Forklift Slots
- Stackable Design
- Safely Transports 4 - 55 Gallon Drums
- Engineered Padeyes

*Also available in DNV.
Drum Carriers for D.O.T. Drums
available upon request.*

TOTE TANK CARRIER

DIMENSIONS 7'9"H x 4'4"W x 4'9"D
EMPTY WEIGHT 1,550 lbs.



FEATURES:

- Maximum Gross Weight 12,000 lbs.
- 4-Point Lift
- Engineered Padeyes
- Forklift Slots
- Stackable Design Empty Only
- Galvanized Coating

SLING RACK CARRIER

DIMENSIONS 4'3"W X 10'3"L X 6'11"H • EMPTY WEIGHT 2,000 lbs.

FEATURES:

- Maximum Gross Weight 12,000 lbs.
- Forklift Slots
- Stackable Design
- Capacity 50 Slings Per Rack
- Engineered Padeyes
- Designed and fabricated with 2.5 to 1 Safety Factor

Available with:

- 50 - 3/4" X 30' Pipe Slings - 14" Standard Eye X 7/8"
- Oversized Thimble with 3/4" Bundler Clamp



GRATING CARRIER

DIMENSIONS 4'3"W X 20'2"L X 2'11"H • EMPTY WEIGHT 1,800 lbs.

FEATURES:

- Maximum Gross Weight 12,000 lbs.
- Engineered Padeyes
- Stackable Design
- 4 Ratchet Straps



Also available in DNV.

“Mixing Tanks You Can Depend On”



50 BARREL DUAL ACTION HYDRAULIC MIXING PACKAGE

TANK DIMENSIONS 14'L x 8'W x 9'H • APPROX. TANK WEIGHT 8,000 lbs.

PUMP AND ENGINE INFORMATION:

371 Detroit Diesel w/PTO and
Hydraulic Power Pack
Electric Start
Drip Pan
Emergency Shut Down
5" x 6" Centrifugal Pump
Muffler Wrap

TANK INFORMATION:

2-4" Fill Lines
2-4" Suction Line
Stairway with Handrails
Large Work Area
Removable Handrails so pallet can be
brought in from two sides
20" Auger with Paddles
4 Shear Breaks Located on Tank Walls
Suction Valve Operable from Work Area



We have all the Flowback Equipment you need.

8 WAY LOW PRESSURE MANIFOLD

8'6" L x 4'6" W x 3'9" H



SPECIFICATIONS:

Empty Weight 2,750 lbs.
6" Butterfly Valves
Camlock Fittings
Galvanized Finish
Padeyes
Forklift Slots
Galvanized Drip Pan
75 psi M.A.W.P.

HIGH PRESSURE MANIFOLD

8'6" L x 4'6" W x 3'9" H



SPECIFICATIONS:

Empty Weight 2,000 lbs.
6" Ball Valves
Hammer Union Connecting
Galvanized Finish
Padeyes
Forklift Slots
Galvanized Drip Pan
400 psi M.A.W.P.



General Terms and Conditions

WARRANTY AND RESPONSIBILITY

It is recognized that conditions in and about any well or work may involve hazards to life and property and obstacles to the functioning of products and the performance of services, and that such conditions are not and never have been subject to inspection or control by Magnum Mud Equipment Co., Inc.

1. Magnum Mud Equipment Co., Inc. warrants only that products, or parts therefor, sold or rented to customers shall be free from defects in materials and workmanship and not that they will accomplish any particular result. Liability under this warranty is limited to replacement of or credit for defective equipment or parts.
2. Services rendered by Magnum Mud Equipment Co., Inc. in connection with the rental or sale of its products consist only of technical advice as to make-up, inspection and operation or use. When any such services are rendered, customer will retain full custody, control and supervision of the work or the well and the conduct or operation thereof, and a representative of customer shall be present with full authority to direct operations.
3. Magnum Mud Equipment Co., Inc. will exert its best efforts to render other services offered by it as requested. No guarantee or representation is made as to results, and charges will be made regardless of results obtained. Magnum Mud Equipment Co., Inc. reserves the right to remove equipment and personnel from the well at any time, if in its opinion, conditions make such action advisable.
4. Customer will hold Magnum Mud Equipment Co., Inc. harmless from any and all liability or claim of liability to any person, firm or corporation for damage to person or property arising out of or in connection with the use of equipment sold or rented hereunder or the rendering of services hereunder, except for damage caused by the willful fault or gross negligence of Magnum Mud Equipment Co., Inc.
5. Magnum Mud Equipment Co., Inc. will hold customer harmless from all damage and from any liability to others for or in connection with damage caused by Magnum Mud Equipment Co., Inc.'s willful fault or gross negligence except in cases where concurrent or contributory fault of customer or customer's agents, servants, employees or contractors shall have contributed to such damage.
6. Magnum Mud Equipment Co., Inc. will hold customer harmless from any liability or injury to employees of Magnum Mud Equipment Co., Inc. except in cases where such injury results from the fault of customer or customer's agents, servants, employees or contractors.
7. Magnum Mud Equipment Co., Inc. will defend at its own cost and expense any suit charging patent infringement in the rental or use of any unaltered rented product and will pay judgement awarded by a court against customer as a result of any such suit, provided the customer is using the product in a manner prescribed by Magnum Mud Equipment Co., Inc. and notifies Magnum Mud Equipment Co., Inc. promptly of such suit and tenders the defense thereof to Magnum Mud Equipment Co., Inc.

8. Products not sold to customer will remain the property of Magnum Mud Equipment Co., Inc. and are not to be repaired or modified without Magnum Mud Equipment Co., Inc.'s consent. If lost or damaged beyond ordinary wear and tear, such products will be charged for as provided in Magnum Mud Equipment Co., Inc.'s current schedule. Any equipment belonging to Magnum Mud Equipment Co., Inc. in customer's possession may be repossessed by Magnum Mud Equipment Co., Inc. upon sixty (60) days notice.

9. All of the preceding terms and conditions shall apply between Magnum Mud Equipment Co., Inc. or any affiliate of Magnum Mud Equipment Co., Inc. and any service company operator, or other party or parties, selling, renting or using Magnum Mud Equipment Co., Inc. products, parts thereof, or services furnished hereunder.

10. The entire liability of Magnum Mud Equipment Co., Inc. including express and implied warranties in connection with its products or services is set forth above, and no one is authorized to waive or amend the same in any particular.

11. Prices, rates or terms are subject to change without notice. Equipment owned by others will be sold, rented or used by Magnum Mud Equipment Co., Inc. under these terms and conditions except where inconsistent with the manufacturer's terms and conditions, when the latter shall prevail.

TERMS OF PAYMENT 30 Days Net. Interest chargeable thereafter.

TAXES AND OTHER CHARGES Any tax based on or measured by the charges or collections for the sale or rental of products or the rendering of services, import duties, documentation charges, freight charges and transfer fees shall be added to the stated price.

CANCELLATION AND RETURNS Orders for products of special design, size or materials are not cancellable after receipt. Special prices will be charged for altered equipment or products made to customer specifications. Credit will not be allowed for products returned without prior written authority.

CHANGE OF DESIGN We reserve the right to change or modify the design of any Magnum Mud Equipment Co., Inc. products without obligation to furnish or install such changes or modifications on products previously or subsequently sold.

RENTAL OF EQUIPMENT Rental charges commence when equipment leaves Magnum Mud Equipment Co., Inc. service base point and continues until returned thereto. If equipment is shipped by carrier to or from lease location, cost of freight will be charged back to customer at Magnum Mud Equipment Co., Inc.'s cost. Costs of restoring rented equipment to first class condition after use will be charged to customer including cleaning of tanks and disposal of any materials left inside of tanks when returned from rental.

SPECIAL PROVISIONS

1. There is a five (5) day minimum rent on most rental equipment.
2. Installation and maintenance of rental equipment and liability for equipment will be lessee responsibility.
3. Service Charges:
 - MMECO Supervisor \$125.00 per hour per man
 - MMECO Service Personnel \$65.00 per hour per man
 - Mileage \$1.10 per mile
 - Food and Lodging Cost plus 15%
 - Third Party Charges at Cost plus 15%
4. Prices published F.O.B. Houma, Louisiana shop and F.O.B. Jennings, Louisiana.

Prices are subject to change without notice.

Disclaimer: Every effort has been made to insure the accuracy of information published herein, however Magnum Mud Equipment Company, Inc. does not guarantee that all equipment supplied by it will have the same specifications as the equipment in this brochure. If a specific or particular piece or type of equipment is required, it is the responsibility of the person ordering to make it known what is required and that no substitutes will be accepted.

MMECO

RAISING THE STANDARDS

24 HOUR SERVICE

CORPORATE OFFICE:

1973 Highway 182
Houma, Louisiana 70364
Phone: 985-872-1755
Fax: 985-872-1786
1-800-230-8265

Jennings, Louisiana
1923 Highway 90 West
Phone: 337-824-8890
Fax: 337-824-8892
1-800-200-8265

Fourchon, Louisiana
1-800-230-8265

Intracoastal City, Louisiana
1-800-200-8265

Venice, Louisiana
1-800-230-8265

Morgan City, Louisiana
1-800-230-8265

Cameron, Louisiana
1-800-200-8265

Galveston, Texas
1-800-200-8265

